

1. Dimensions:

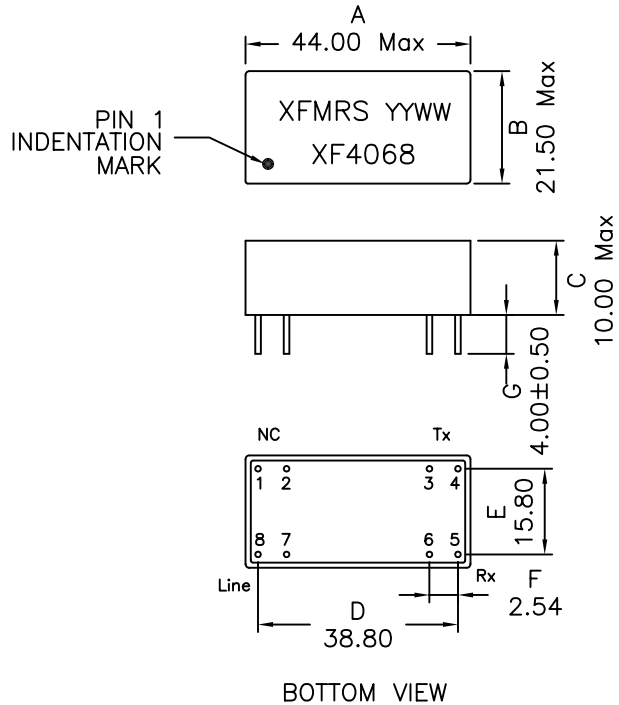

BOTTOM VIEW

2. Schematic:

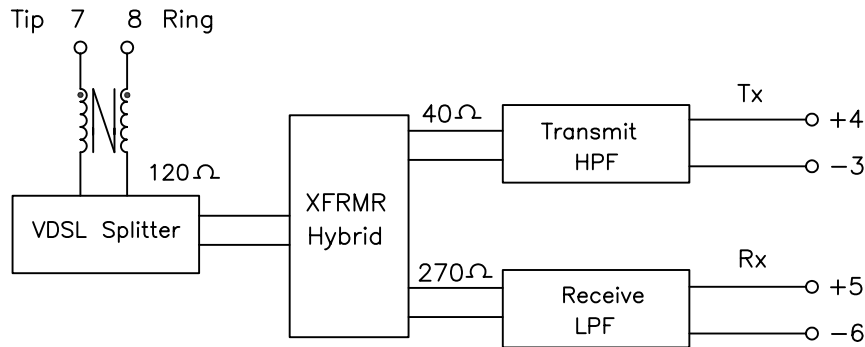

3. Electrical Specifications: @25°C

Description	Passband Frequency	Insertion Loss (Max)	Return Loss (Min)	Stopband Frequency	Attn. (Min)	Impedance
VDSL Splitter/Hybrid	1.0MHz-7.9MHz	0.8 dB	10 dB	10KHz-100KHz	70 dB	120 Ohms
	950KHz-1.0MHz	1.5 dB	8 dB	100KHz-500KHz	55 dB	120 Ohms
				600KHz-700KHz	15 dB	120 Ohms
				20MHz-40MHz	15 dB	120 Ohms
RX LPF	900KHz-3.0MHz	1.2 dB	12 dB	4.5MHz-7.9MHz	50 dB	270 Ohms
TX HPF	4.5MHz-7.9MHz	0.8 dB	10 dB	900KHz-3.0MHz	10 dB	40 Ohms

Notes:

1. Solderability: Leads shall meet MIL-STD-202, Method 208D for solderability.
2. Flammability: UL94V-0
3. ASTM oxygen index: > 28%
4. Temperature rating: 155°C. UL file E151556
5. Operating Temperature Range: All listed parameters are to be within tolerance from -0°C to +85°C

XFMRS Inc UNLESS OTHERWISE SPECIFIED TOLERANCES: .xx ±0.25 Dimensions in MM	Title: VDSL FILTER/HYBRID SOLUTION	
	P/N: XF4068	REV. A
	DWN. 李小锋	Jul-02-02
	CHK. 廖玉坤	Jul-02-02
SHT 1 OF 1	APP. Joe Huff	Jul-02-02